



# Technical Bulletin

## iForks Nut Replacement Kit 6159831

This sheet describes replacing the nuts on Cascade-Ravas iForks. Early production units use serrated locknuts and washers to fasten the fork shoe to the fork. These units require replacement of the serrated locknuts and washers with prevailing torque locknuts to limit maintenance issues.

**IMPORTANT:** Do not remove fork shoe. Do not remove capscrews.

- 1 Raise forks.
- 2 Remove locknuts and washers from bottom of forks and discard.
- 3 Install new kit 6159831 prevailing torque locknuts. Tighten to a torque of 83 ft.-lbs. (112 nm). Use an 18 mm socket and 10 mm Allen wrench.

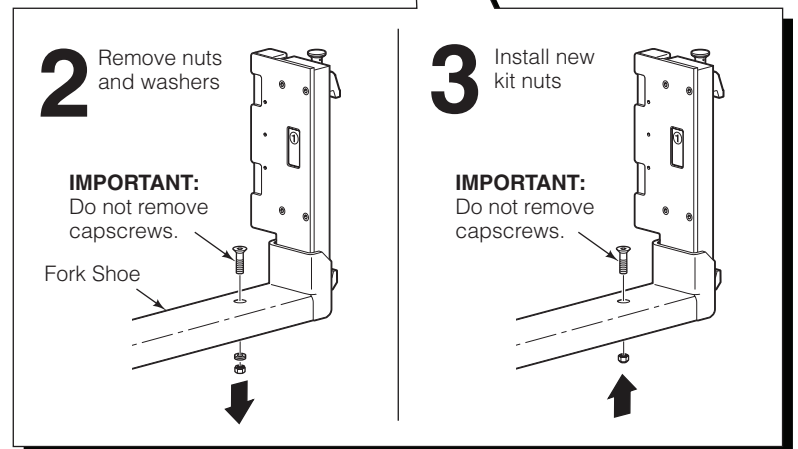
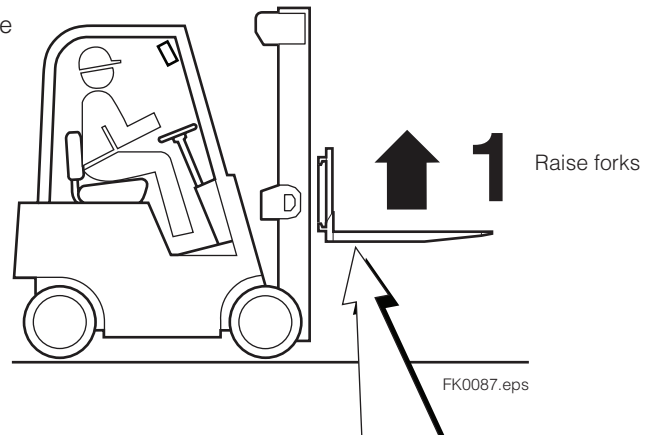

**NOTE:** This information should not be interpreted as the basis for warranty claims unless so designated.

**cascade**<sup>®</sup>  
**corporation**

**For Technical Support . . .**

Call: 1-800-CASCADE (227-2233)

**OR**

Write: Cascade Corporation, PO Box 20187, Portland, OR 97294-0187

**To Order Parts . . .**

Call: 1-888-CASCADE (227-2233)

**OR**

Write: Cascade Corporation, 2501 Sheridan Ave., Springfield, OH 45505