



Installation Instructions

Electronic Pressure Regulator Valves 374540, 374541 & 374542

Install these pressure relief valves when it is necessary to limit the clamping force of the attachment arms or to vary the clamping force from load to load. Each cartridge can be adjusted to relieve pressure between 500 and 2300 psi. The valve maximum flow rate is 25 GPM.

- 1 Determine a convenient location to mount the valve on the truck cowl, mast or in the driver's compartment. The valve should be mounted as close as possible to the truck valves. See Figure 1. Install 5/16 in. capscrews to fasten the valve in position.
- 2 Assemble the components as shown in the schematic below.

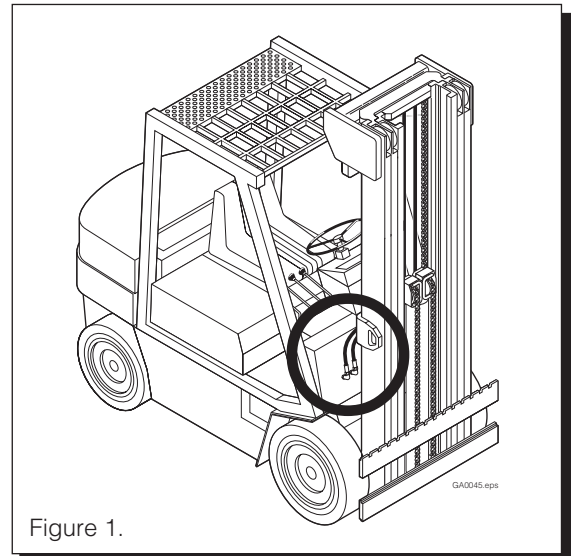
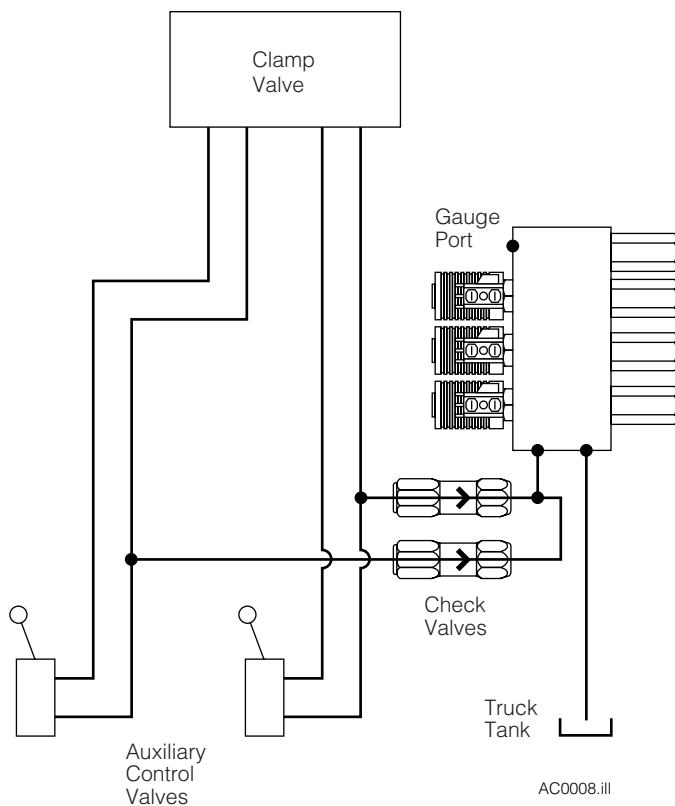

Figure 1.

Independent arm control shown.



Part No. 374545

cascade®

For Technical Assistance and to Order Parts . . .

Call: 1-800-CAS-CADE or 503-669-6300

FAX: 503-669-6338

Write: Cascade Corporation, PO Box 20187, Portland, OR 97220