



# Technical Bulletin

## 25F Paper Roll Clamp and 30E Rotator Bearing Service Kit 201811

This sheet describes procedures to install a new rotator bearing assembly. The location of the bearing assembly grease fitting has been changed, which will require the baseplate to be drilled. The new location of the grease fitting allows easy lube access from the rear of the attachment.

### Attachment Removal

- 25F Roll Clamps** – Rotate the clamps to position the contact pads perpendicular to the ground. Extend the arm outside the width of the frame.  
**30E Rotators** – Rotate the attachment to position the forks parallel to the ground.
- Remove the lower hooks.  
**Bolt On Hooks** - Remove the lower mounting hooks. For reassembly, tighten the capscrews to a torque of 105-115 ft.-lbs. (142-155 Nm)  
**Quick Change Hooks** - Pull out the locking pins, slide the hooks down and reinstall the pins in the lower holes.



**WARNING:** Before removing any hoses, relieve pressure in the hydraulic system. Turn the truck off, then open the auxiliary control valve(s) several times in both directions.

- Disconnect and plug the hydraulic hoses to the attachment. Tag the hoses for reassembly.
- Tilt the mast forward. Remove the attachment from the lift truck and place on a pallet. **Rotators** – Remove the forks and lay the attachment face down on a pallet.

**NOTE:** This information should not be interpreted as the basis for warranty claims unless so designated.

Part No. 201812

# cascade®

For Technical Assistance . . .

Call: 1-800-CASCADE or 503-669-6300

OR

Write: Cascade Corporation, P.O. Box 20187, Portland, OR 97220

To Order Parts . . .

Call: 513-322-1199

OR

Write: Cascade Corporation, P.O. Box 360, Springfield, OH 45505

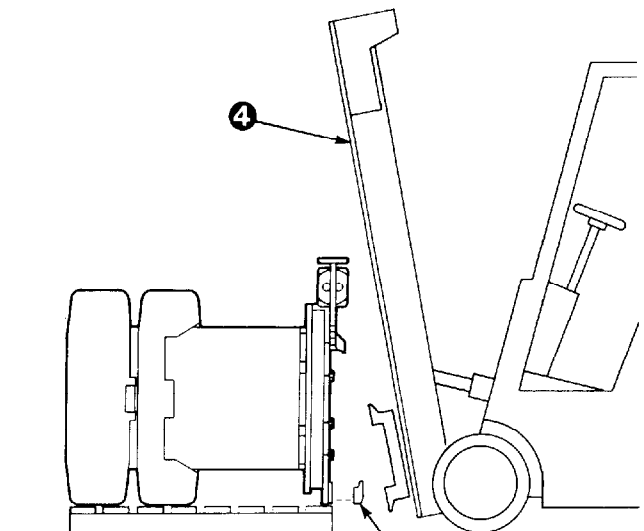

**Bolt on Hooks** ②

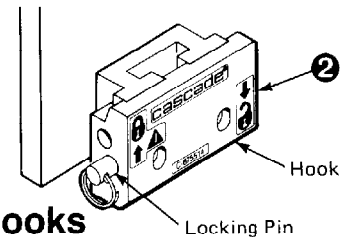

**Quick Change Hooks**

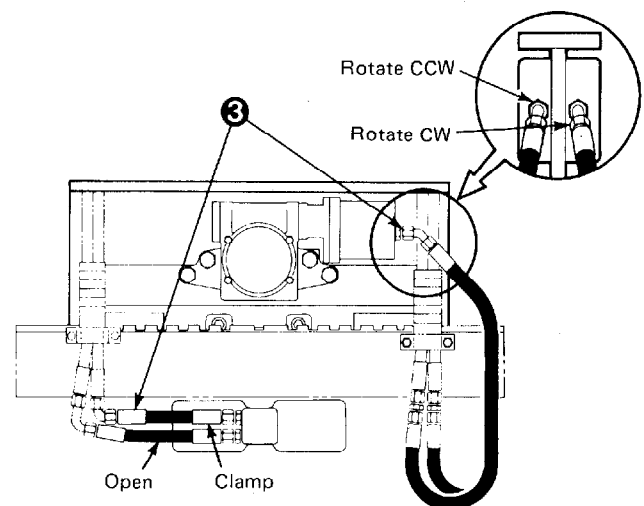

# Drive Group Removal

- ❶ Remove the attachment from the truck as described in Attachment Removal.
- ❷ Remove the four capscrews fastening the drive group to the baseplate. For reassembly, tighten the capscrews to a torque of 150-160 ft.-lbs. (200-220 Nm).
- ❸ For reassembly, reverse the above procedures except as follows:
  - After the drive group has been installed, check the oil level in the drive assembly. The oil level must be up to the end cover center plug. To add oil, remove the breather cap (on the 90° fitting) . Fill through the 90° fitting with Cascade Gear Lube 656300 or equivalent SAE 90 wt. lube (AGMA "mild" 6 EP Gear Oil) until lube begins to run from the end cover center plug hole.

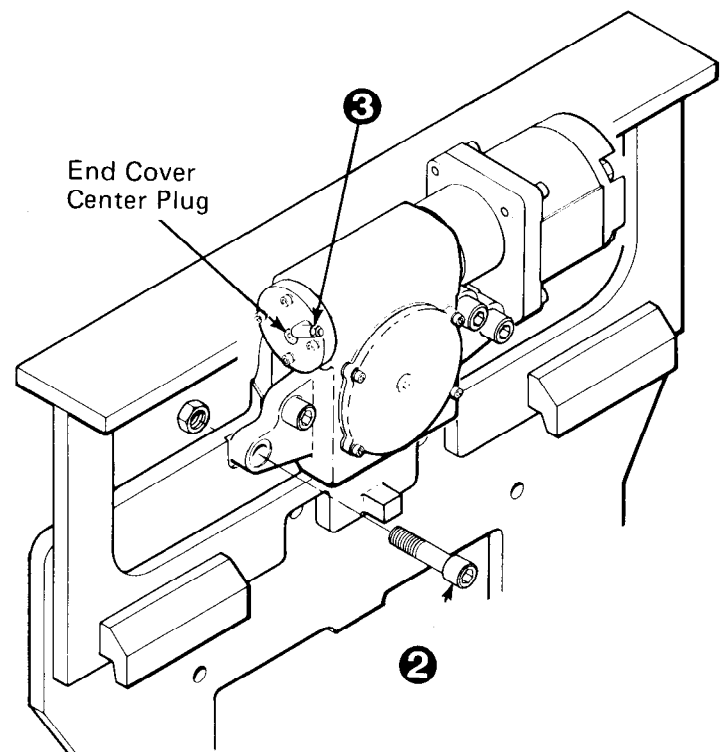

# Bearing Assembly Service

- ❶ Attach an overhead hoist to the baseplate. Remove the capscrews fastening the baseplate to the bearing assembly. For reassembly, tighten the capscrews to a torque of 190-205 ft.- lbs. (260-280 Nm).



**WARNING:** Make sure your hoist has a rated capacity of 1000 lbs. (450 kg).

- ❷ Lift away the baseplate.
- ❸ Attach two eyebolts (16 mm) to the bearing assembly. Attach an overhead hoist.
- ❹ Remove the capscrews fastening the bearing assembly to the faceplate. Lift away the bearing assembly.
- ❺ Install the new bearing assembly to the faceplate. Tighten the faceplate capscrews to half torque value 40 ft.-lbs. (55 Nm) using the pattern shown below. Tighten to full torque value, 75-85 ft.-lbs. (100-110 Nm).
- ❻ Apply waterproof chassis grease (Whitmore Omni-Task EP2 or NLGI grade 2) to the bearing assembly gear teeth.

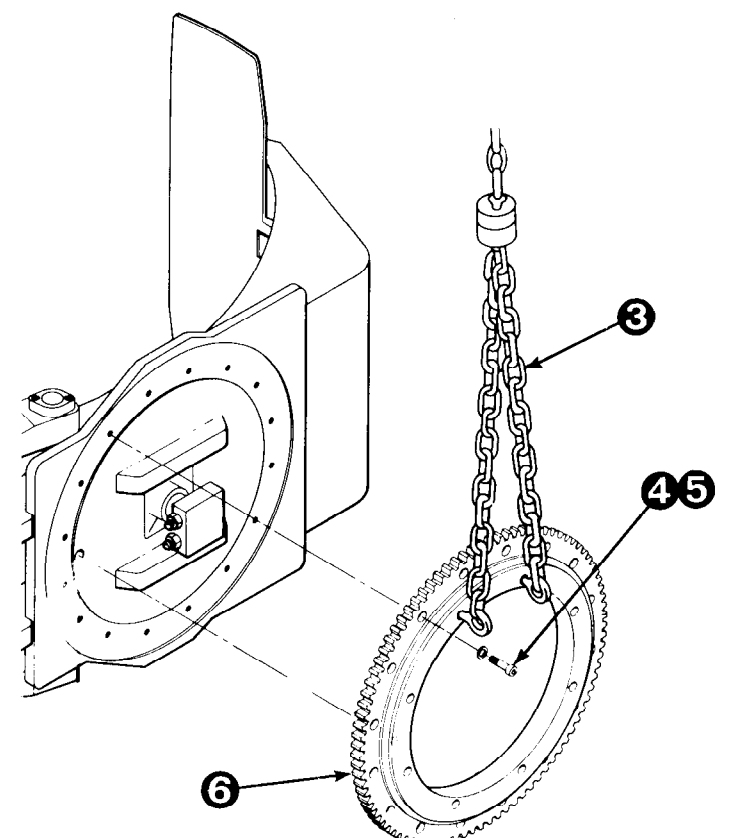
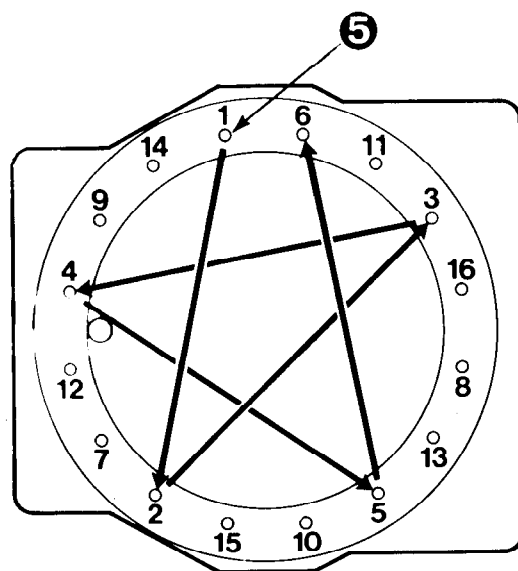
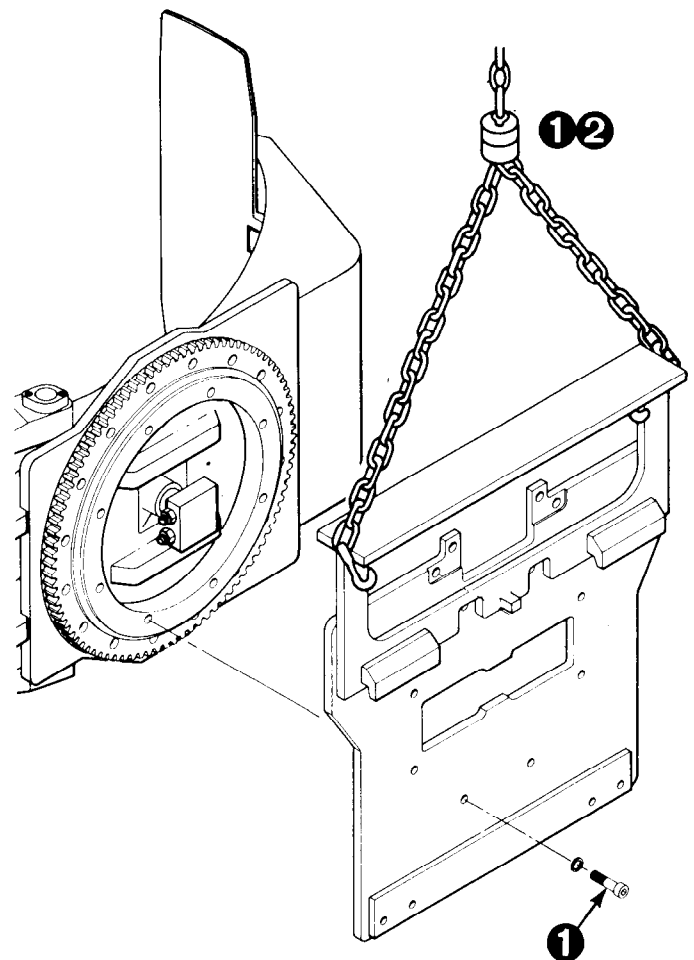

**7** Lay the baseplate on its back. Use the template below to center punch and drill a .75 in. (19 mm) hole through the baseplate for the new grease fitting location. Use a magnetic base drill attachment.

**8** For reassembly, reverse the above procedures except as follows:

- Install the grease fitting extension to the bearing assembly inner race grease fitting hole.
- Align the grease fitting extension with the new access hole in the baseplate.
- Tighten the baseplate capscrews to half torque value 100 ft.-lbs. (140 Nm) using the pattern shown below. Tighten to full torque value, 190-205 ft.-lbs. (260-280 Nm).
- Install the 90° grease fitting to the grease fitting extension through the baseplate access hole. Point the 90° grease fitting upward when tightened.
- After remounting the attachment on the lift truck, apply waterproof chassis grease (Whitmore Omni-Task EP2 or NLGI grade 2) to the 90° grease fitting. Lube then rotate the clamp to distribute the grease. Apply grease and rotate several times.

Template  
New grease fitting hole.

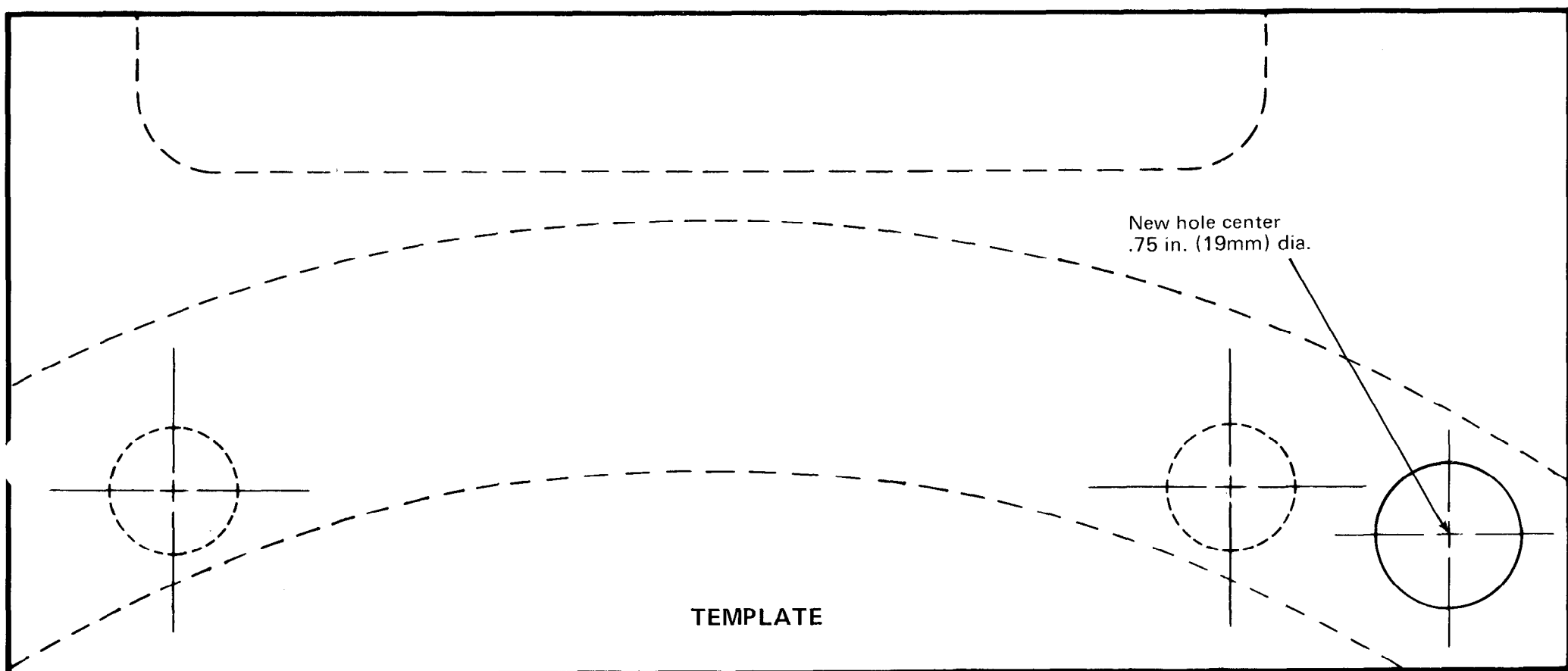
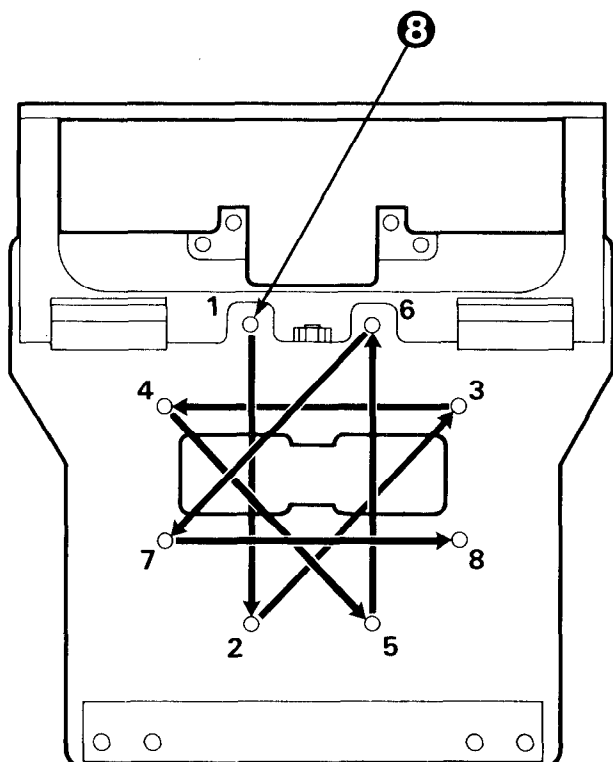
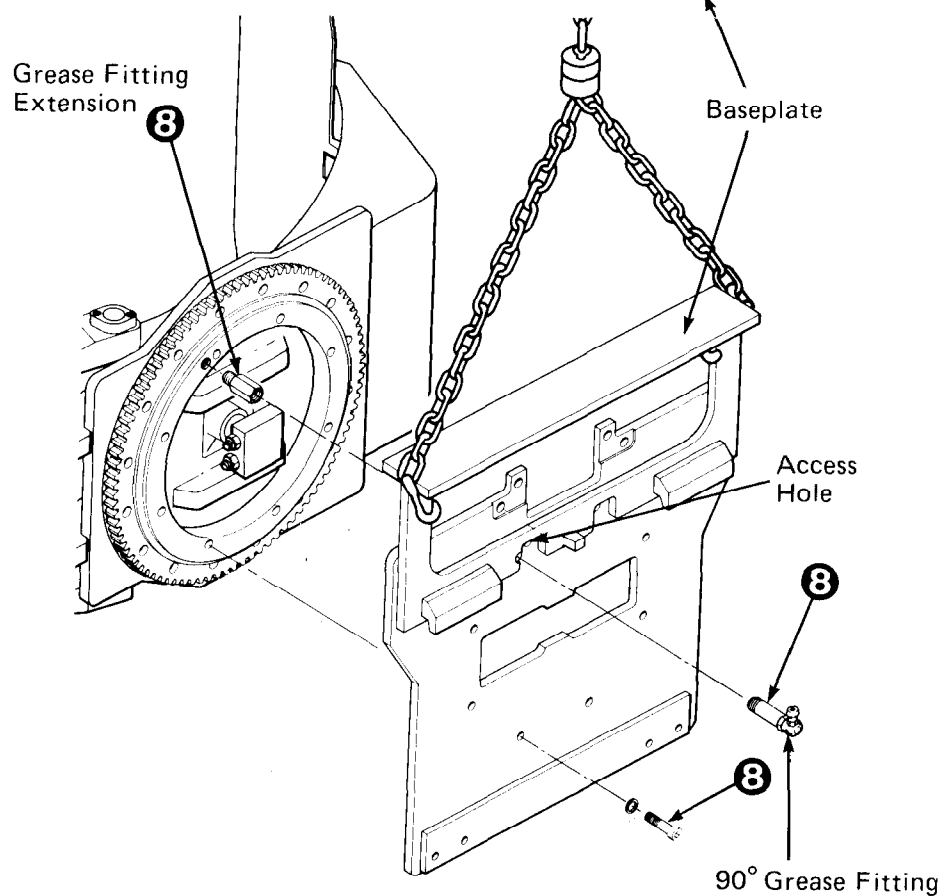
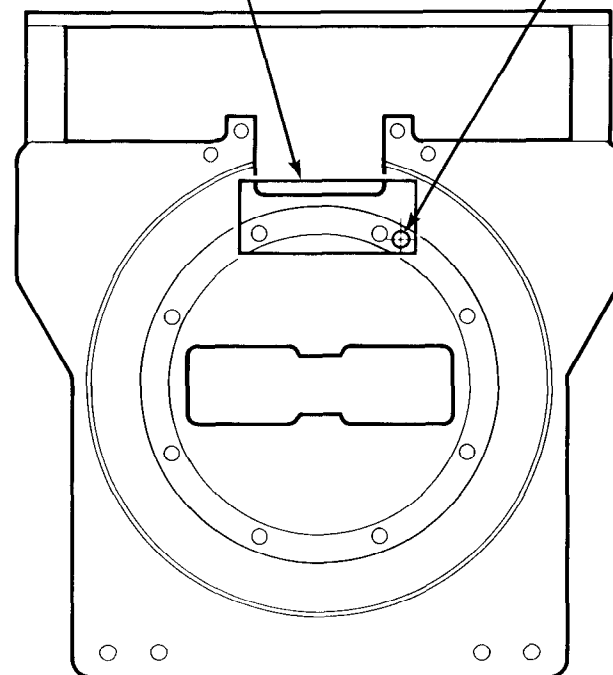

**Do you have questions you need answered right now? Call your nearest Cascade Service Department.**

#### **AMERICAS**

**Cascade Corporation  
U.S. Headquarters**  
2201 NE 201st  
Fairview, OR 97024-9718  
Tel: 800-CASCADE (227-2233)  
Fax: 888-329-8207

**Cascade Canada Inc.**  
5570 Timberlea Blvd.  
Mississauga, Ontario  
Canada L4W-4M6  
Tel: 905-629-7777  
Fax: 905-629-7785

**Cascade do Brasil**  
Rua João Guerra, 134  
Macuco, Santos - SP  
Brasil 11015-130  
Tel: 55-13-2105-8800  
Fax: 55-13-2105-8899

#### **EUROPE-AFRICA**

**Cascade Italia S.R.L.  
European Headquarters**  
Via Dell'Artigianato 1  
37030 Vago di Lavagno (VR)  
Italy  
Tel: 39-045-8989111  
Fax: 39-045-8989160

**Cascade (Africa) Pty. Ltd.**  
PO Box 625, Isando 1600  
60A Steel Road  
Sparton, Kempton Park  
South Africa  
Tel: 27-11-975-9240  
Fax: 27-11-394-1147

#### **ASIA-PACIFIC**

**Cascade Japan Ltd.**  
2-23, 2-Chome,  
Kukuchi Nishimachi  
Amagasaki, Hyogo  
Japan, 661-0978  
Tel: 81-6-6420-9771  
Fax: 81-6-6420-9777

**Cascade Korea**  
121B 9L Namdong Ind.  
Complex, 691-8 Gojan-Dong  
Namdong-Ku  
Inchon, Korea  
Tel: +82-32-821-2051  
Fax: +82-32-821-2055

**Cascade-Xiamen**  
No. 668 Yangguang Rd.  
Xinyang Industrial Zone  
Haicang, Xiamen City  
Fujian Province  
P.R. China 361026  
Tel: 86-592-651-2500  
Fax: 86-592-651-2571

**Cascade India Material  
Handling Private Limited**  
No 34, Global Trade Centre  
1/1 Rambaugh Colony  
Lal Bahadur Shastri Road,  
Navi Peth, Pune 411 030  
(Maharashtra) India  
Phone: +91 020 2432 5490  
Fax: +91 020 2433 0881

**Cascade Australia Pty. Ltd.**  
1445 Ipswich Road  
Rocklea, QLD 4107  
Australia  
Tel: 1-800-227-223  
Fax: +61 7 3373-7333

**Cascade New Zealand**  
15 Ra Ora Drive  
East Tamaki, Auckland  
New Zealand  
Tel: +64-9-273-9136  
Fax: +64-9-273-9137

**Sunstream Industries  
Pte. Ltd.**  
18 Tuas South Street 5  
Singapore 637796  
Tel: +65-6795-7555  
Fax: +65-6863-1368

