



Parts Manual

Model _____ Layer Picker _____

Catalog Number _____ 30A41671 _____

cascade®
corporation

For Technical Assistance call: 800-227-2233, Fax: 888-329-8207

To Order Parts call: 888-227-2233, Fax: 888-329-0234

OR

Write: Cascade Corporation, P.O. Box 20187, Portland, OR 97220

Internet: www.cascorp.com

Safety Decals

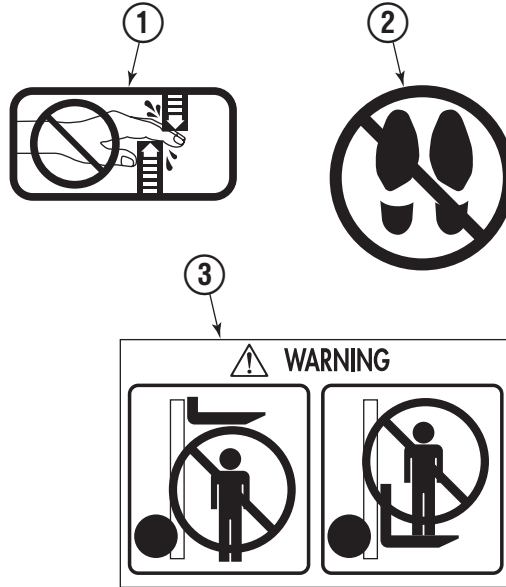
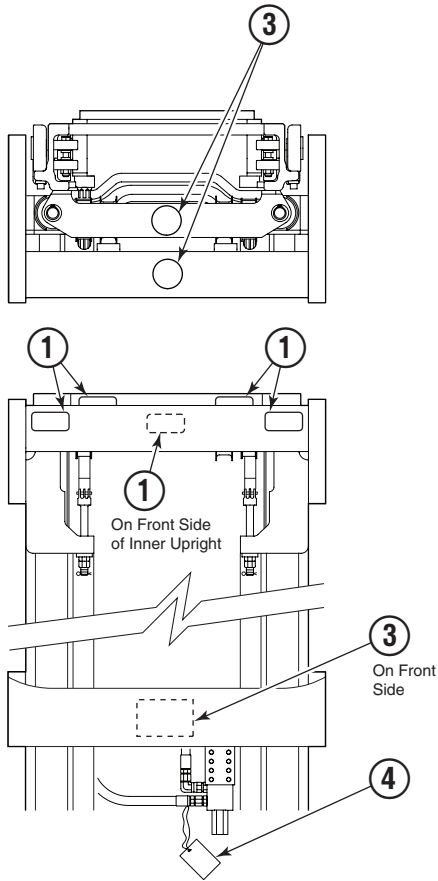

LP0064.eps

REF	QTY	PART NO.	DESCRIPTION
1	5	665595	No Hand Hold Decal
2	2	679150	No Step
3	1	684166	WARNING
4	1	200798	WARNING-Trapped Air

Publications

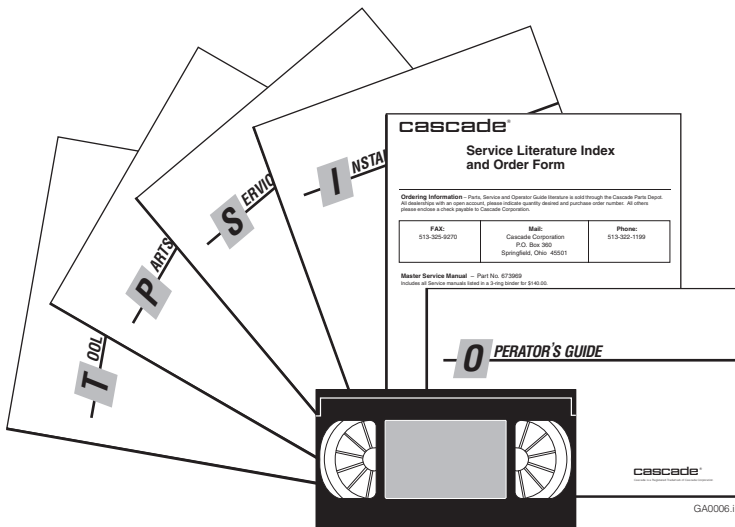

30A	
PART NO.	DESCRIPTION
230444	Service Manual
222225	Operators Guide
222964	Installation Instructions
679929	Tool Catalog
673964	Literature Index Order Form

Mounting/Frame Assembly

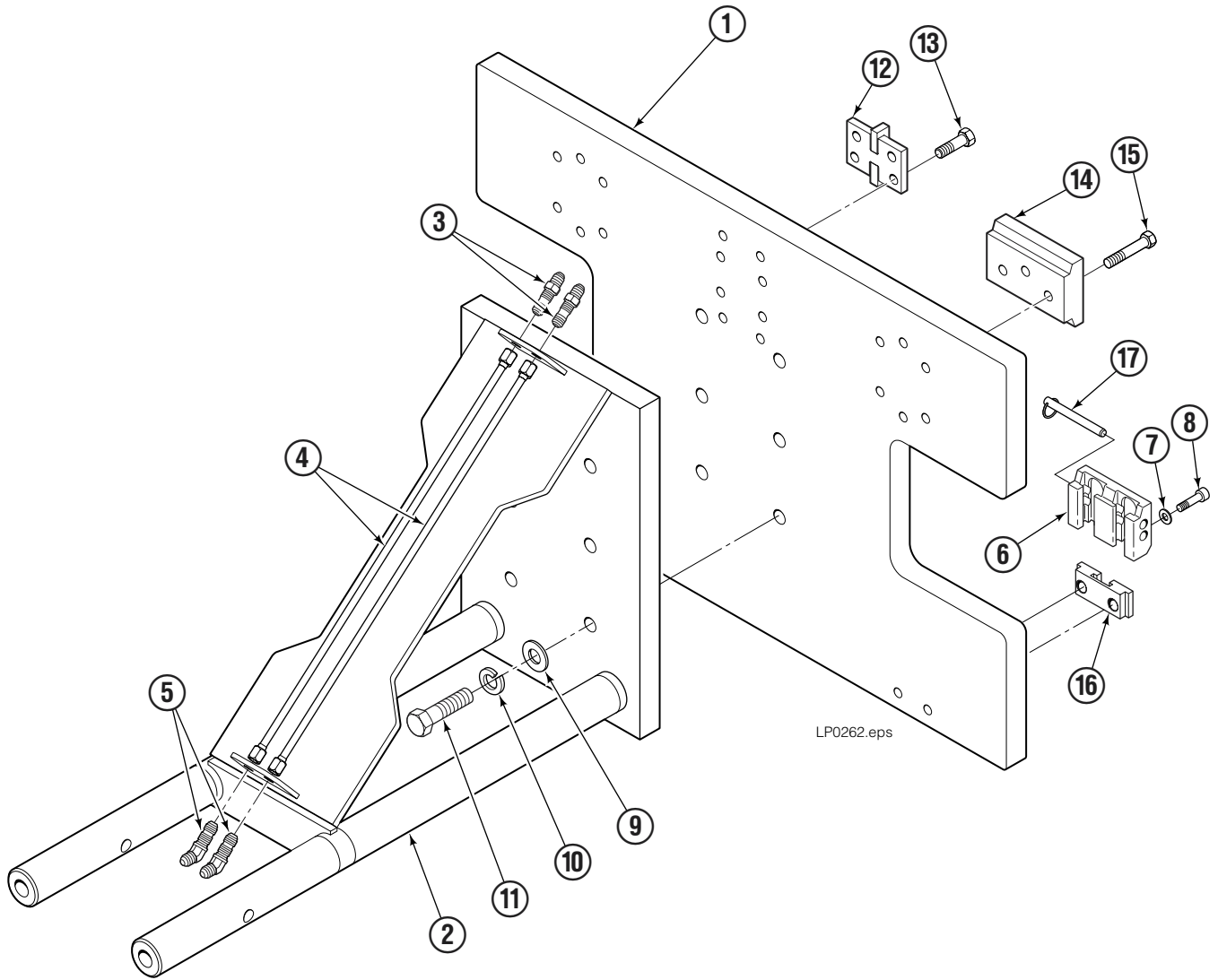

REF	QTY	PART NO.	DESCRIPTION
		6122048	Mounting/Frame Assembly
1	1	6115449	Mounting Plate
2	1	3018831	Frame
3	2	2375	Fitting, 6-6
4	2	3018912	Tube
5	2	2492	Fitting, 6-6
6	2	675514	Lower Hook
7	10	684586	Washer, M16
8	4	211180	Capscrew, M16 x 30
9	6	215419	Washer, M20
10	6	681467	Lockwasher, M20
11	6	768582	Capscrew, M20 x 80
12	1	3005793	Key Plate
13	4	684633	Capscrew, M16 x 50
14	2	3005795	Upper Hook
15	6	751511	Capscrew, M16 x 55
16	2	675515	Guide
17	2	678832	Pin

Clamp Assembly

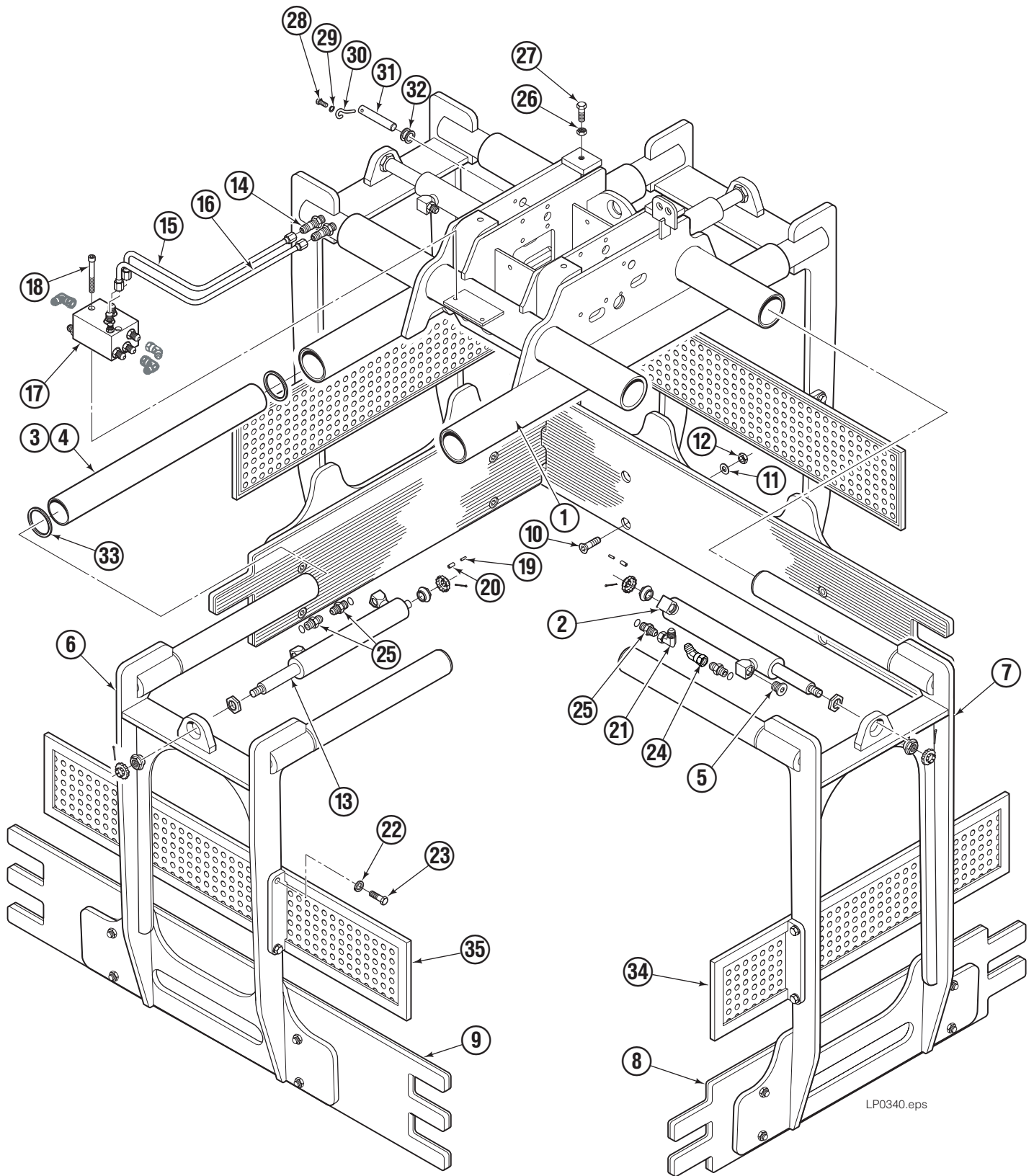

LP0340.eps

Clamp Assembly

REF	QTY	PART NO.	DESCRIPTION
		6139542	Clamp Assembly
1	1	6139536	Frame (28321)
2	2	6139527	Cylinder – LA ♦
3	2	21066-0925	Bushing
4	2	21066-0696	Bushing
5	4	602580	Plug
6	2	6139553	Arm – Short (12166)
7	2	6139552	Arm – Long (12166)
8	2	6139481	Contact Pad, 40 x 9 in.
9	2	6139482	Contact Pad, 48 x 9 in.
10	16	768707	Capscrew, M12 x 40
11	16	200456	Washer, M12
12	16	205979	Nut, M12
13	2	6139526	Cylinder – SA ♦
14	2	2375	Fitting, 6-6
15	1	6116409	Tube
16	1	6116410	Tube
17	1	219694	Valve ●
18	2	768802	Capscrew, M8 x 70
19	4	7861	Roll Pin – Inner
20	4	7962	Roll Pin – Outer
21	6	2680	Fitting, 6-6
22	16	683822	Lockwasher, M12
23	16	763021	Capscrew, M12 x 30
24	2	605230	Fitting, 6-6
25	8	611288	Fitting, 6-6
26	4	769151	Nut, M24
27	4	768601	Capscrew, M24 x 80
28	2	787372	Capscrew, M8 x 20
29	2	787398	Washer, M8
30	2	689954	Eye Pin
31	2	218169	Pin
32	8	399469	Shim
33	8	222901	Retaining Ring
34	2	6139483	Load Support Panel
35	2	6127144	Load Support Panel

♦ See Cylinder page for parts breakdown.

● See Valve page for parts breakdown.

Reference: SK-12403.

Valve Assembly

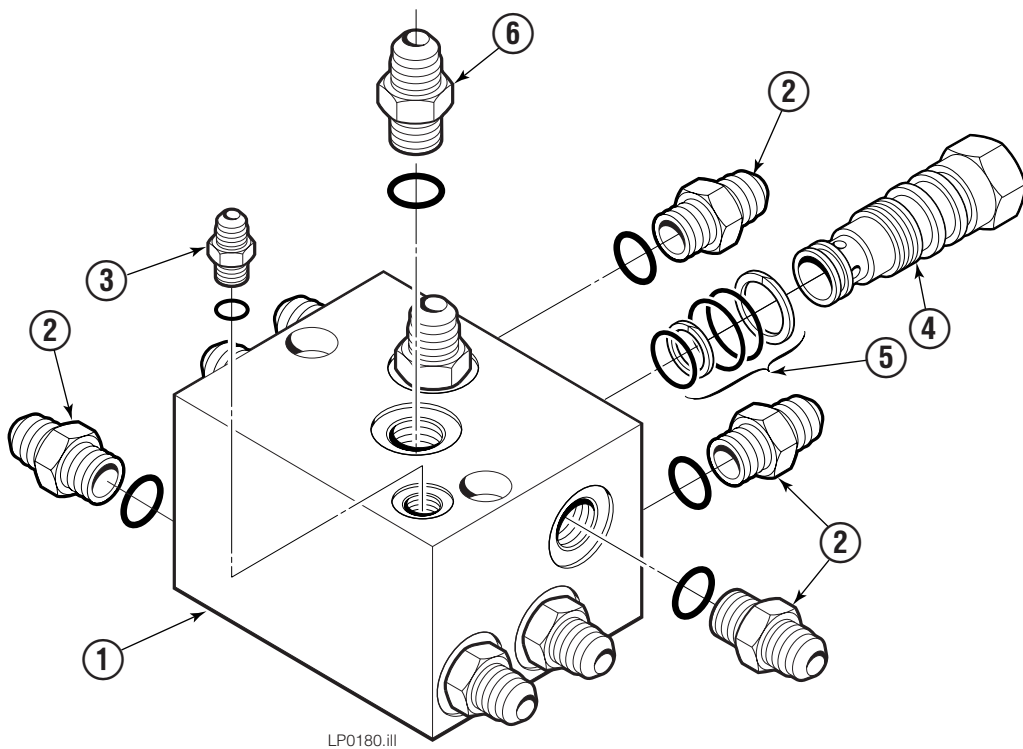

REF	QTY	PART NO.	DESCRIPTION
		219694	Valve Assembly
1	1	219693	Valve Body
2	8	611288	Fitting, 6-8
3	1	617915	Fitting, 4-4
4	1	6038929	Check Valve - PO
5	1	667516	Seal Kit
6	2	601377	Fitting, 8-8

Cylinder Assembly

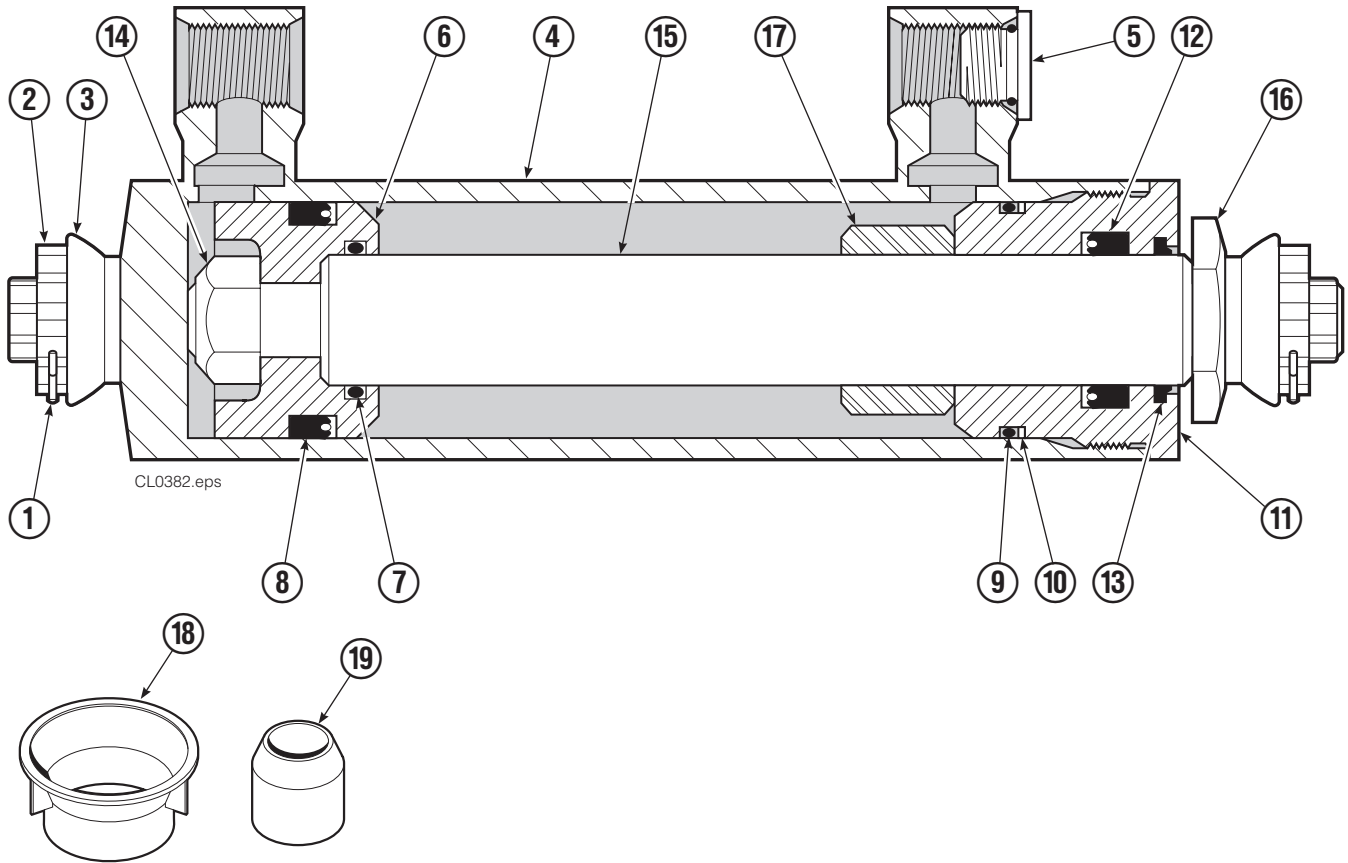

REF	QTY	PART NO.	DESCRIPTION
		6139526	Cylinder Assembly
1	2	6510	■ Cotter Pin
2	2	667624	■ Nut Retainer
3	2	667625	■ Nut
4	1	6139528	Shell
5	1	602580	Fitting
6	1	559702	Piston
7	1	2716	◆ O-Ring
8	1	662450	◆ Seal
9	1	2722	◆ O-Ring
10	1	615126	◆ Back-Up Ring
11	1	413799	Retainer
12	1	662448	◆ Seal
13	1	636853	◆ Wiper
14	1	667623	Nut
15	1	6139530	Rod
16	1	667626	Washer
17	1	6113961	Spacer
18	1	671047	◆ Seal Loader - Piston
19	1	671051	◆ Seal Loader - Retainer
		560729	Service Kit

■ Included in Nut Service Kit 668926.

◆ Included in Service Kit 560729.

Reference: ST-0283, ST-0284.

Cylinder Assembly

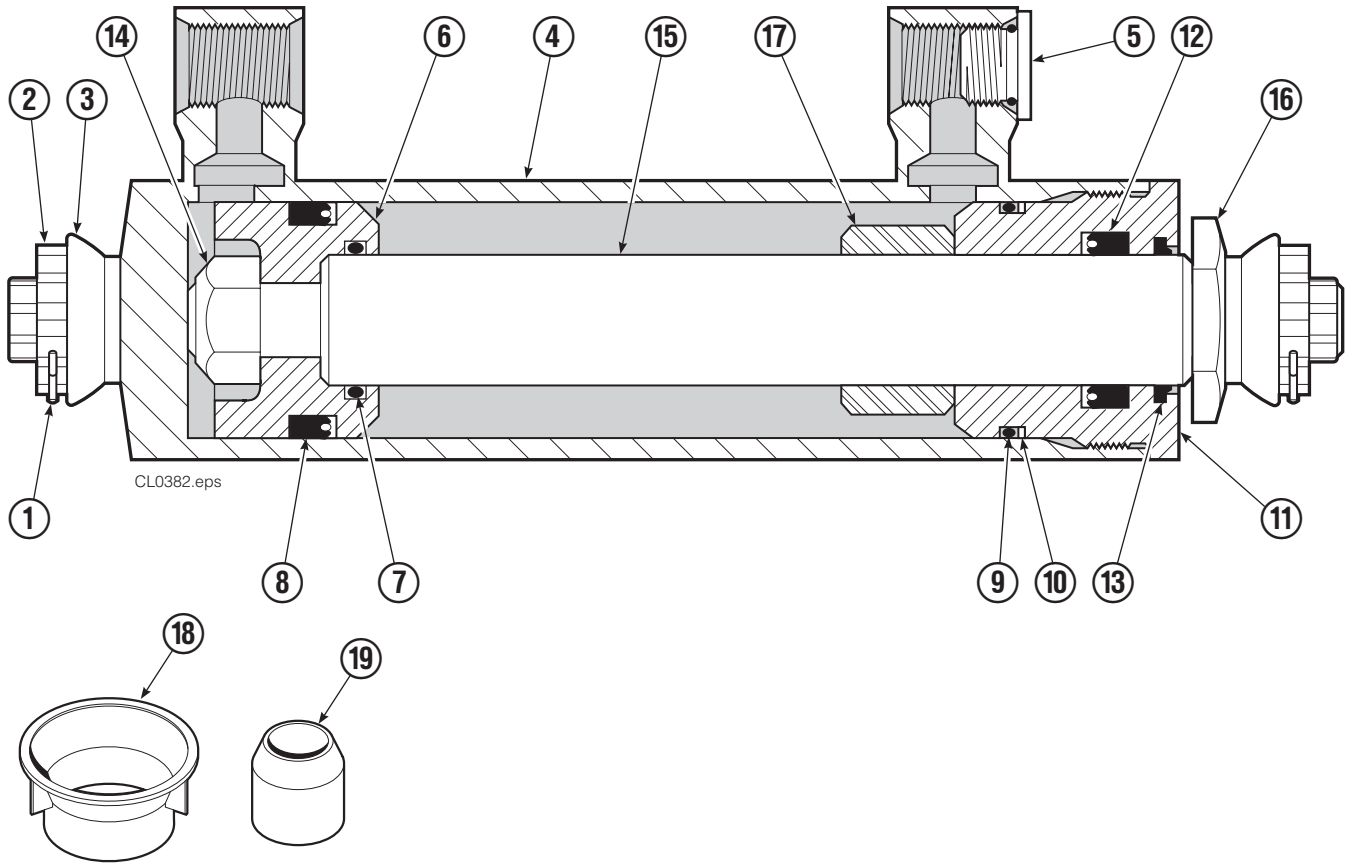

REF	QTY	PART NO.	DESCRIPTION
		6139527	Cylinder Assembly
1	2	6510	■ Cotter Pin
2	2	667624	■ Nut Retainer
3	2	667625	■ Nut
4	1	6139529	Shell
5	1	602580	Fitting
6	1	559702	Piston
7	1	2716	◆ O-Ring
8	1	662450	◆ Seal
9	1	2722	◆ O-Ring
10	1	615126	◆ Back-Up Ring
11	1	413799	Retainer
12	1	662448	◆ Seal
13	1	636853	◆ Wiper
14	1	667623	Nut
15	1	6139531	Rod
16	1	667626	Washer
17	1	3005466	Spacer
18	1	671047	◆ Seal Loader - Piston
19	1	671051	◆ Seal Loader - Retainer
		560729	Service Kit

■ Included in Nut Service Kit 668926.

◆ Included in Service Kit 560729.

Reference: ST-0283, ST-0284.

Contact Pad Spacer Group

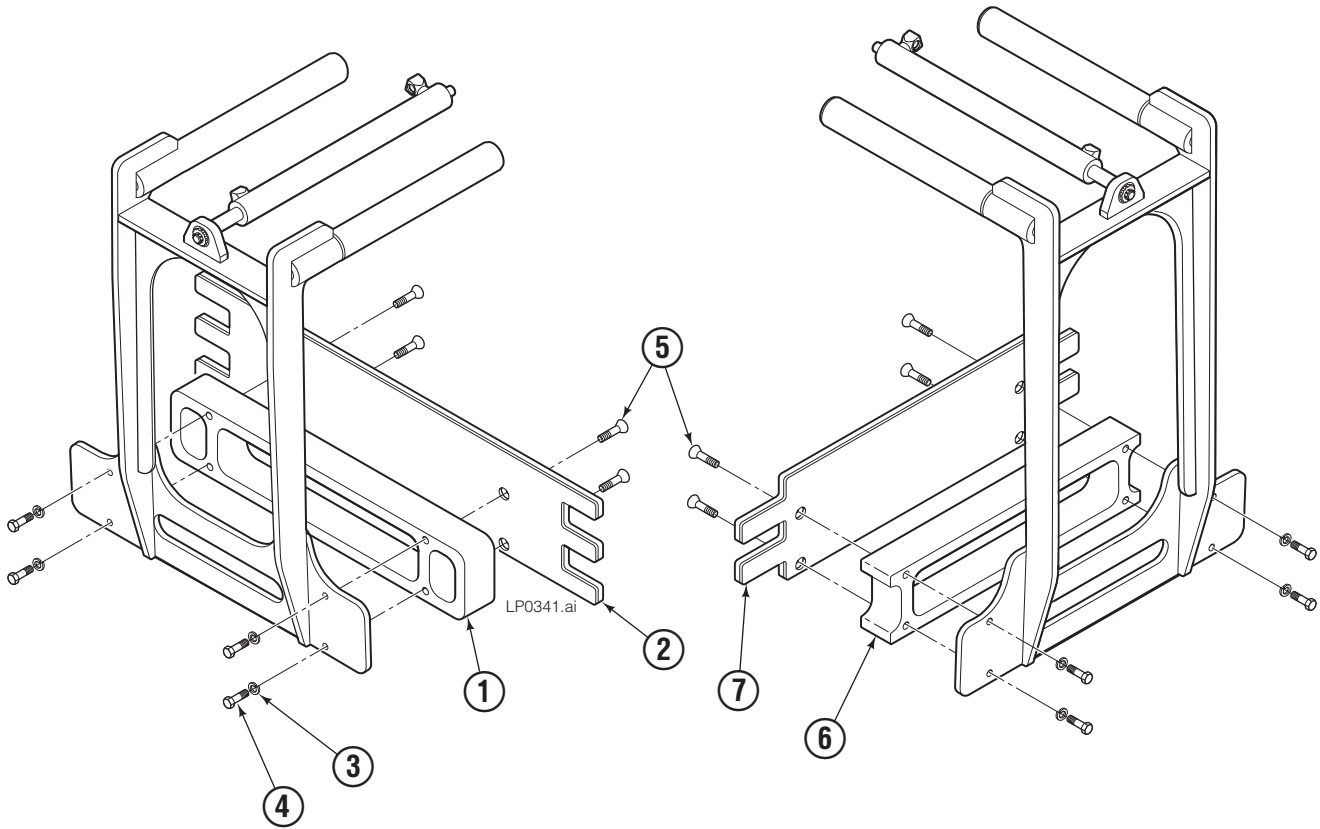

30A			
REF	QTY	PART NO.	DESCRIPTION
		6139534	Contact Pad Spacer Group
1	2	6124892	Pad Spacer, 30 x 6
2	2	6139523	Contact Pad, 41 x 9
3	16	683822	Washer, M12
4	16	768554	Capscrew, M12 x 35
5	16	768706	Capscrew, M12 x 35
6	2	6139525	Pad Spacer, 25 x 6
7	2	6139524	Contact Pad, 34 x 9

Hose Group

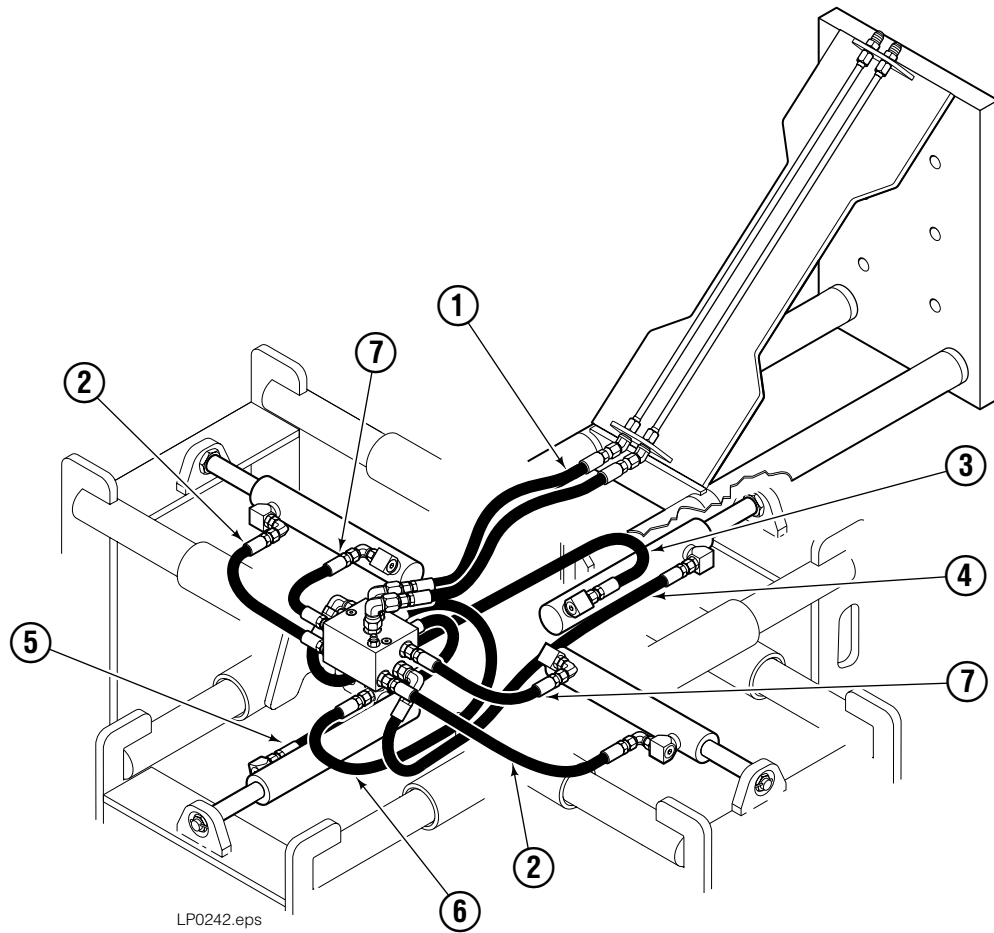

LP0242.eps

REF	QTY	PART NO.	DESCRIPTION
		6100368	Hose Group - modified
1	1	6011624	Hose, Tinline 32.0 in.
2	2	221654	Hose, 35.5 in.
3	1	221652	Hose, 30.0 in.
4	1	205226	Hose, 34.25 in.
5	1	201256	Hose, 21.0 in.
6	1	686472	Hose, 25.5 in.
7	2	221653	Hose, 24.5 in.



Installation Instructions

Four-Position Pressure Relief Valve 660412

This sheet provides installation instructions for the Four-Position Pressure Relief Valve 660412. The valve enables up to four (4) pressure selections, allowing the clamping force to be varied from load to load. Three pressure relief cartridges can be adjusted to relieve pressure between 100 and 3000 psi, a fourth position blocks flow to all relief cartridges enabling straight-through truck relief pressure. Maximum flow rate through the valve is 20 GPM.

- 1 Determine a convenient location on the truck cowl or safety cage upright, within safe reach and view of the driver (see illustration opposite). Use the mounting hole dimensions shown to mount the valve securely.

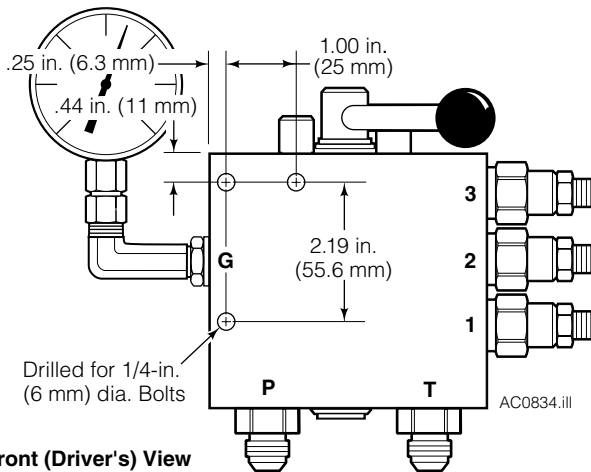

Front (Driver's View)



WARNING: Before removing hydraulic hoses, relieve pressure in the Attachment hydraulic system. Turn the truck off and move the auxiliary control lever several times in both directions.

- 2 Attach hoses and fittings between the Pressure Relief Valve, truck auxiliary valve, truck tank, and attachment valve using the diagram and hydraulic schematic. **No. 8 hoses and fittings with 13/32 in. (10 mm) minimum ID. recommended.**

CAUTION: A dedicated return-to-tank line is required from the relief valve 'TANK' port to the truck tank. Return Line Adapter Kits available:

Part No. 214062 (.75 in. dia. line)
Part No. 211745 (1.0 in. dia. line)
Part No. 214066 (1.25 in. dia. line)

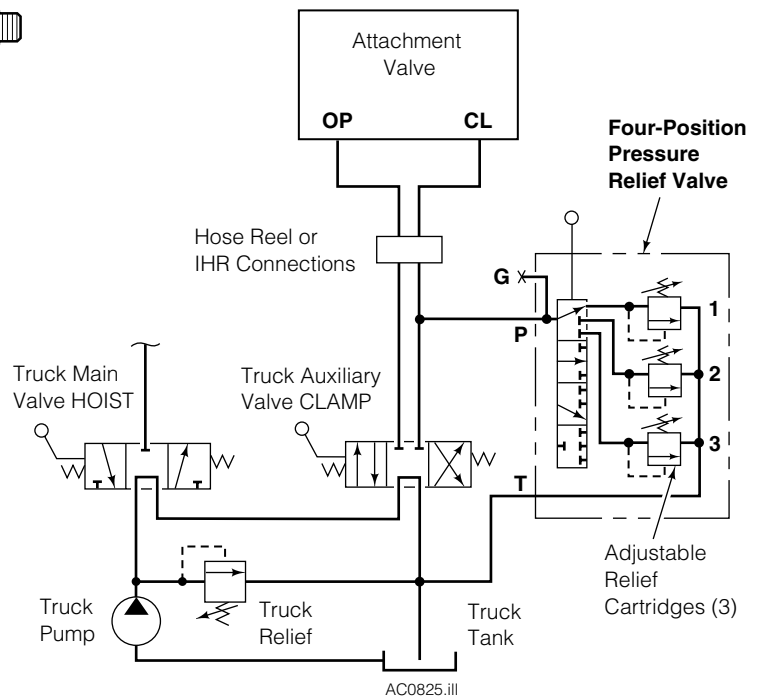
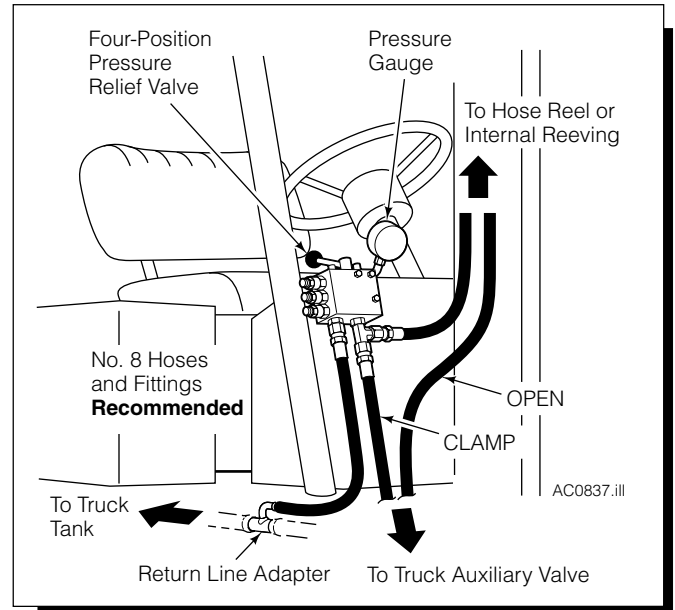

cascade[®]
corporation

For Technical Support . . .

Call: 1-800-227-2233 Fax: 1-888-329-8207
 Internet: www.cascorp.com
 Write: Cascade Corporation, PO Box 20187, Portland, OR 97294

To Order Parts . . .

Call: 1-888-227-2233 Fax: 1-888-329-0234
 Internet: www.cascorp.com
 Write: Cascade Corporation, 2501 Sheridan Ave., Springfield, OH 45505

- 3** Four basic stop configurations are shown in the illustration opposite (relief valve mounted as shown in this sheet). Many different configurations are possible by rearranging the stops, or by sliding the lever within the valve spool. Position the stops for desired movement of the lever depending on your specific requirements.

IMPORTANT: Numbers stamped around base of lever correspond to relief valve cartridge selected. Positions 1 and 2 are duplicated and can be selected 180 degrees opposite from each other. Position 'X' blocks the flow to all relief valve cartridges so the valve has no effect. Truck relief pressure is then delivered to the attachment.

- 4** To preset the Valve relief cartridges, install a 5000 psi (345 bar) pressure gauge (Cascade Part No. 664158) in the Valve gauge port.

Sample Settings*

3-Position	4-Position
Pos. X – Not Available	Pos. X – 2300 (Truck Pressure)
Pos. 1 – 1400 psi	Pos. 1 – 1800 psi
Pos. 2 – 1600 psi	Pos. 2 – 1600 psi
Pos. 3 – 1800 psi	Pos. 3 – 1400 psi

* **IMPORTANT: Cartridges are not factory pre-set.** Pressures must be adjusted for your application. Four (4) positions not available when Light Bar Switch is mounted on valve.

- 5** Shift the valve lever index pointer to position '1' stamped on the valve body.
- 6** Loosen the jam nut on the No. 1 relief cartridge. Adjust the relief cartridge (3/16-in. Allen hex wrench) inward (CW) to raise pressure or outward (CCW) to lower the pressure.
- 7** Clamp up on the load and check the pressure. Readjust as required. Tighten the jam nut.
- 8** Shift the valve lever pointer to position '2' stamped on the valve body. Repeat step 6 and 7 for No. 2 relief cartridge.
- 9** Shift the valve lever pointer to position '3' stamped on the valve body. Repeat step 6 and 7 for No. 3 relief cartridge.
- 10** With the valve lever pointer at position 'X', all ports to the relief valve cartridges are blocked, and the valve has no effect. Pressure to the attachment is determined by truck system relief pressure. The 'X' position selection may be blocked by positioning the stops as shown.

CAUTION: Do not remove the rotating spool from the valve body. Permanent damage will occur due to the spring-loaded detents and will void the warranty. Replace valve as a complete assembly.

Replacement Parts

Qty	Description	Part No.
3	Relief Cartridge with Seals	661676
3	Seal Service Kit	669597

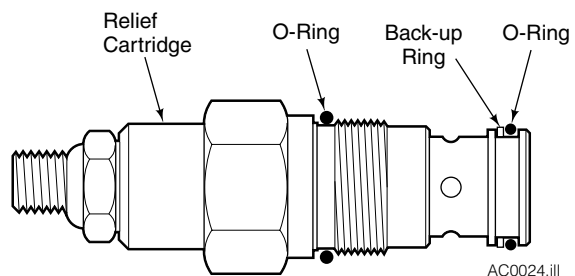
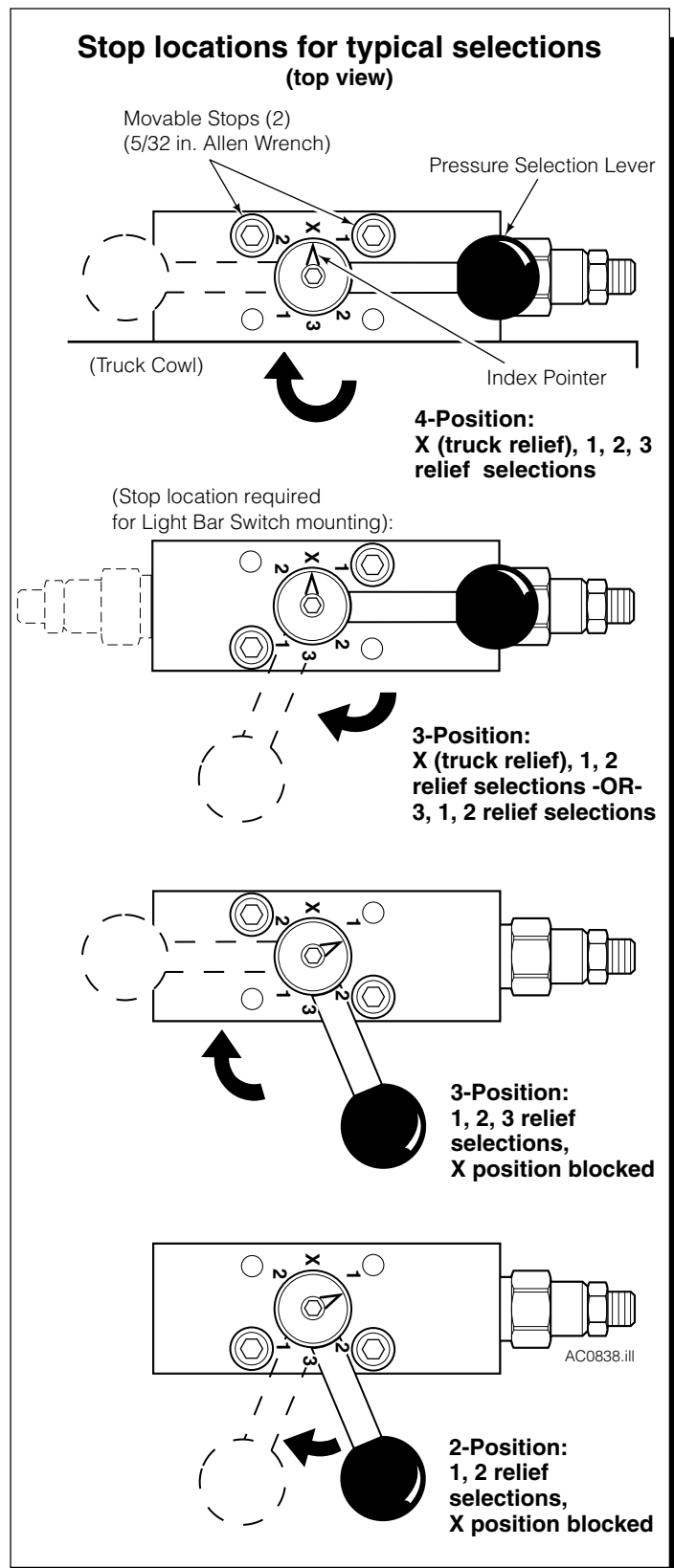

Do you have questions you need answered right now? Call your nearest Cascade Parts Department. Visit us online at www.cascorp.com

**Cascade Corporation
U.S. Headquarters**
2201 NE 201st
Fairview, OR 97024-9718
Tel: 800-CASCADE (227-2233)
FAX: 888-329-8207

Cascade Canada Inc.
5570 Timberlea Blvd.
Mississauga, Ontario
Canada L4W-4M6
Tel: 905-629-7777
FAX: 905-629-7785

Cascade GmbH
Niederwippekühl 1
58579 Schalksmühle
Germany
Tel: 02355-50900
FAX: 02355-509020

Cascade Finland
A. Petreliuksenkatu 3
01370 Vantaa
Finland
Tel: 09-8361925
FAX: 09-8361935

**Cascade N.V.
Benelux Sales and Service**
Damsluisweg 56
PO Box 3009
1300 El Almere
The Netherlands
Tel: 036-5492950
FAX: 036-5492974

Cascade Kenhar Ltd.
3 Kelbrook Road
Parkhouse Ind. Estate
Openshaw,
Manchester M11 2DD
England
Tel: 0800-243015
FAX: 0161-4384055

**Sales Scotland
Macade Systems Ltd.**
18 Melford Road
Righead Ind. Estate
Bellshill ML4 3LR
Scotland
Tel: 01698-845777
FAX: 01698-845888

Cascade (Africa) Pty. Ltd.
PO Box 625, Isando 1600
60A Steel Road
Sparton, Kempton Park
South Africa
Tel: 27-11-975-9240
FAX: 27-11-394-1147

Cascade Scandinavia AB
Hammarvägen 10
PO Box 124
S-56723 Vaggeryd
Sweden
Tel: 039-336950
FAX: 039-336959

**Cascade France
S.A.R.L. MHP**
1D Rue De Charaintru BP 18,
91360 Epinay-Sur-Orge
France
Tel: 01-6454-7500
FAX: 01-6454-7501

Cascade Hispania S.A.
Carrer 5, Sector C
Zona Franca Duanera
Poligono de la Zona Franca
08040 Barcelona, Spain
Tel: 93-264-07-30
FAX: 93-264-07-31

Cascade Italia S.R.L.
Via Dell'Artigianato 1
37050 Vago di Lavagno (VR)
Italy
Tel: 39-045-8989111
FAX: 39-045-8989160

Movimenta Lda.
Parque Industrial
Vale do Alecrim, Lote 108
2950-403 Palmela
Portugal
Tel: 351-212387340
FAX: 351-212387349

**Sales Switzerland
Fahrzeugbedarf**
8810, Horgen
Switzerland
Tel: 01-7279797
FAX: 01-7279798

Sales Poland
Targowa 35/61
03-728 Warszawa
Tel: 022-619 00 49
FAX: 022-619 00 49
Mobile Tel: 0501-27 29 55

Sales Russia
EMCG Material Handling
Equipment
Moscow
Tel: 095-795-2400
FAX: 095-795-2475
Email: emcg@emcg.ru

Cascade Japan Ltd.
5-5-41,
Torikai Kami
Settsu, Osaka
Japan, 566
Tel: 81-726-53-3490
FAX: 81-726-53-3497

Cascade Korea
121B 9L Namdong Ind.
Complex, 691-8 Gojan-Dong
Namdong-Ku
Inchon, 405-310 Korea
Tel: 82-32-821-2051
FAX: 82-32-821-2055

Cascade Australia
1445 Ipswich Road
Rocklea, QLD 4107
Australia
Tel: 1-800-227-223
FAX: 617-3373-7333

Cascade New Zealand
15 Ra Ora Drive
East Tamaki, Auckland
New Zealand
Tel: 64-9-273-9136
FAX: 64-9-273-9137

Cascade-Xiamen
No. 668 Yangguang Rd.
Xinyang Industrial Zone
Haicang, Xiamen City
Fujian Province
P.R. China 361026
Tel: 86-592-651-2500
FAX: 86-592-651-2571

**Sunstream Industries
Pte Ltd.**
No. 3 Tuas Link 1
2263
Singapore
Tel: 65-6863-3488
FAX: 65-6863-1368

**Cascade do Brasil
Distribuidora de Garras
e Garfos LTDA**
Rua João Guerra, 134
Macuco, Santos - SP
Brasil 11015-130
Tel: 55-13-2105-8800
Fax: 55-13-2105-8899

