

Technical Bulletin

Mast Hoist Control Accumulator Kit 331804 Installation Instructions

Models: 30C, 45C, 55C and 80C Cascade Viewmast® II Free-Lift Roller Masts

1. Locate the accumulator bracket on the side of the mast outer channel using the dimensions shown.
2. Clean the surface to be welded with a wire brush. Remove paint and other contaminants.
3. Use E-7018 (5/32" dia.) low hydrogen electrodes per AWS 5.1. Electrodes must be in good condition. Bake as required to remove all moisture per manufacturer's procedures.
4. Use DC reverse polarity or an AC welding machine. Set the amperage at 175 amps.
5. Preheat the bracket and channel weld area to ambient temperature. **DO NOT** weld in a drafty area.
6. Weld the bracket to the mast using horizontal welds as shown. **DO NOT WELD ON THE BACK OF THE CHANNEL.** Let welds slow cool.

(Continued)

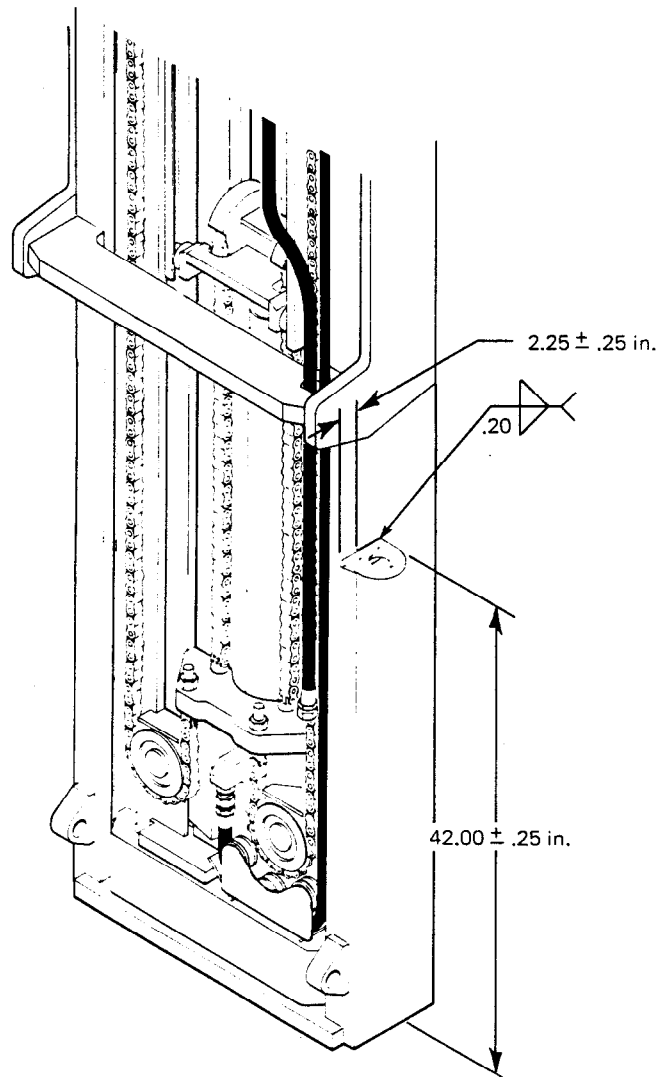

NOTE: This information should not be interpreted as the basis for warranty claims unless so designated.

cascade®

For Technical Assistance . . .

Call: 1-800-CASCADE or 503-669-6300

OR

Write: Cascade Corporation, PO Box 20187, Portland, OR 97220

To Order Parts . . .

Call: 513-322-1199 FAX: 513-325-9270

OR

Write: Cascade Corporation, 2501 Sheridan Ave., Springfield, OH 45505

7. Remove slag and inspect the welds. Clean the weld area and repaint with Cascade paint part no. 668209.
8. Assemble the accumulator, fittings and hose to the mast cylinder hoist control hose as shown.
9. Raise and lower the mast slowly to check for hydraulic leaks and hose interferences. If the mast cylinder appears to be "spongy", bleed air from the cylinder as specified in the service manuals listed below:

Models 30C, 55C, 80C - Service Manual 667433

Model 45C - Service Manual 669223

