



Technical Bulletin

60G Paper Roll Clamp Upper Mounting Plate Capscrew Replacement Service Kit 399300

This sheet provides instructions for the removal and replacement of upper mounting plate capscrews for 60G Paper Roll Clamps equipped with ITA Class IV 0 and 2 degree mounting groups 390690 and 391366. The existing capscrews are too long and could possibly lose the tightened torque after the attachment has been in operation.

- 1 Rotate the attachment to position the contact pads perpendicular to the ground. Extend the arms outside the width of the frame.
- 2 Remove the lower mounting hooks. For reassembly, tighten the hook capscrews to a torque of 125 ft.-lbs. (170 Nm).
- 3 Place the attachment on a pallet. Tilt the truck mast forward and lower the carriage to disengage the truck from the attachment. Leave the hydraulic hoses connected.
- 4 Back the truck away from the attachment just far enough to access the upper mounting plate capscrews.

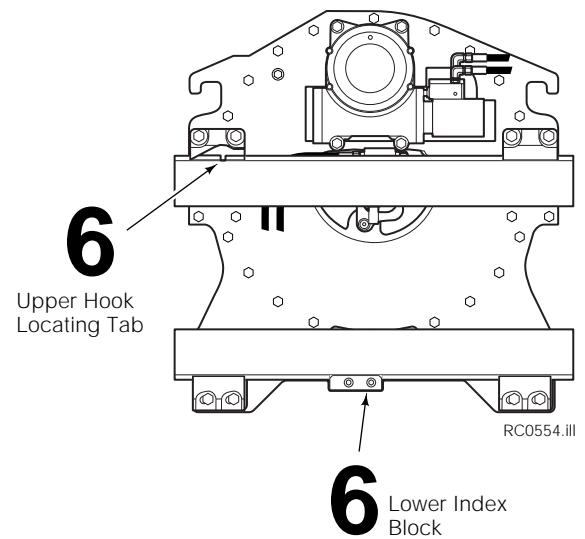
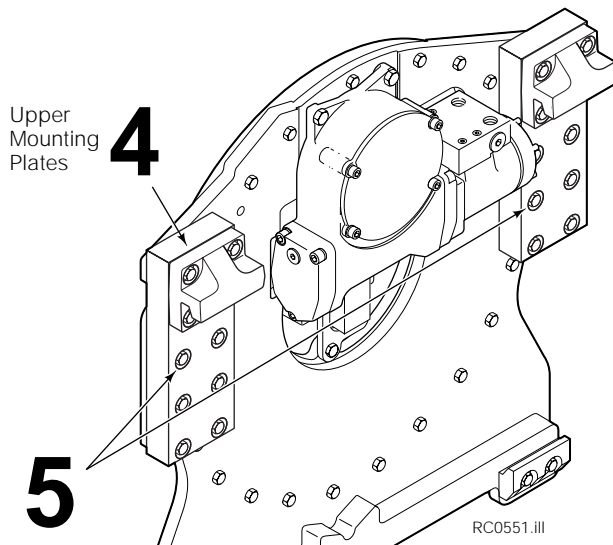
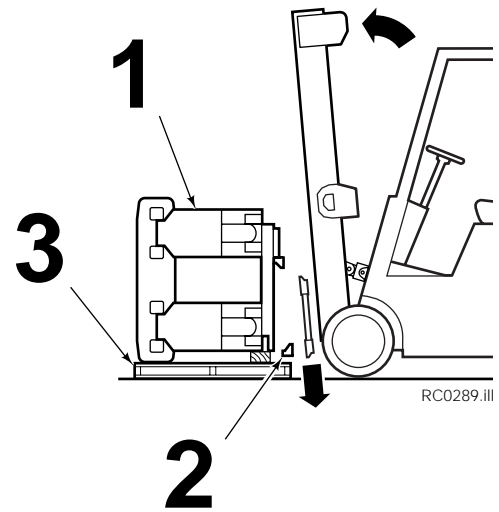

- 5 Remove the 12 capscrews fastening the mounting plates to the baseplate. Install the new capscrews supplied in the service kit. Tighten the capscrews to a torque of 125 ft.-lbs. (170 Nm).
- 6 Reinstall the attachment on the truck. Make sure the upper hook locating tab and lower index block are properly engaged with the carriage.

NOTE: This information should not be interpreted as the basis for warranty claims unless so designated.

cascade®

For Technical Support . . .

Call: 1-800-227-2233

OR

Write: Cascade Corporation, P.O. Box 20187, Portland, OR 97220

To Order Parts . . .

Call: 1-888-227-2233

OR

Write: Cascade Corporation, 2501 Sheridan Ave., Springfield, OH 45505