

Technical Bulletin

Single-Double Inner Fork Control Gas Cylinder Identification and Modifications

This Bulletin describes how to identify and modify Single-Double Pallet Handlers with early style inner fork control gas cylinders. When worn or damaged the gas cylinders can disengage from the anchor bracket and cause machine damage or personal injury. The two different style gas cylinder configurations have a service kit or brackets available to securely retain the gas cylinders. Order the appropriate service kit or brackets and install as shown.

Configuration 1 - Non Current

If you have this style inner fork control cylinders, order bracket kit 6116937 to secure the cylinders.

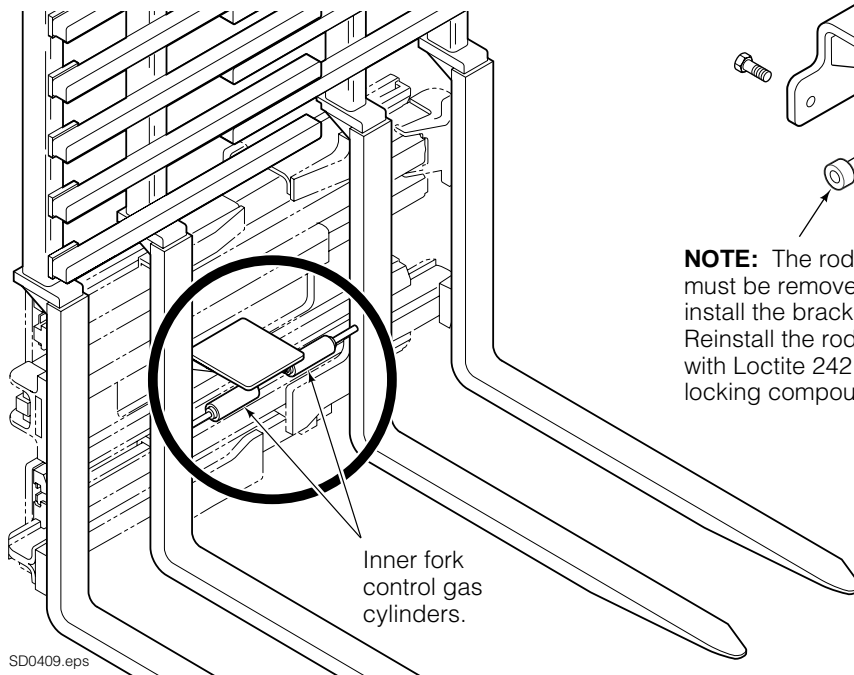
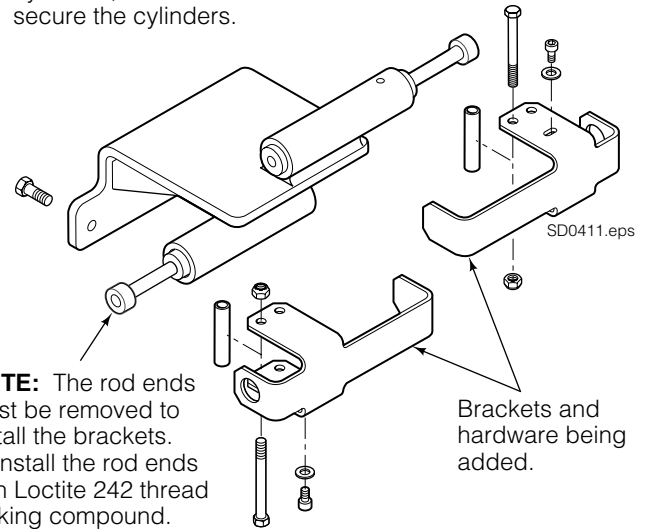

Configuration 2 - Non Current

If you have this style inner fork control cylinders, order 2 brackets 6112201 to secure the cylinders.

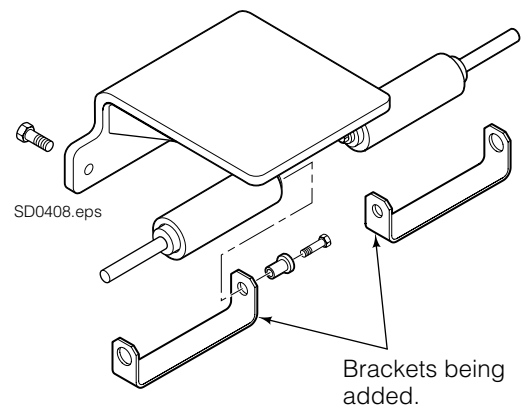

Current Design

No modifications required

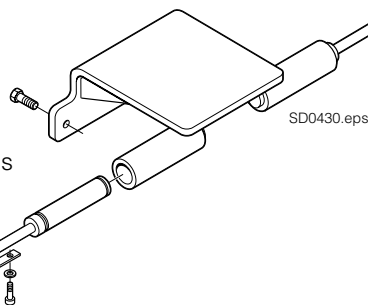

NOTE: This information should not be interpreted as the basis for warranty claims unless so designated.

cascade® corporation

For Technical Support . . .

Call: 1-800-227-2233 Fax: 1-888-329-8207
 Internet: www.cascorp.com
 Write: Cascade Corporation, PO Box 20187, Portland, OR 97294

To Order Parts . . .

Call: 1-888-227-2233 Fax: 1-888-329-0234
 Internet: www.cascorp.com
 Write: Cascade Corporation, 2501 Sheridan Ave., Springfield, OH 45505