



Installation Instructions

Crown CAN Reader Kit 6812924 for User Supplied Light Bars

This sheet contains installation information for the CAN Reader for Light Bars.

This kit includes a CAN Reader, DC to DC Converter (for Trucks 24–48V), Voltage Filter (for electric trucks), wire and connectors for connecting a user supplied Light Bar.

Installation

CAUTION: Consult the Lift Truck OEM for proper + power source connection.

- 1 Determine a suitable mounting location for the CAN Reader where it will be easily accessible for wiring connections. Mount unit securely to a metal panel if possible, away from any heat sources such as engine drivetrain, exhaust manifold, etc.
- 2 Connect cable ends to the power supply.
12V Systems – Connect the positive wire from the cable harness to a 12V switched power source, and the ground wire to a chassis ground.

24V–48V Systems – Connect the CAN Reader power wires, DC-to-DC Converter and Voltage Filter to fused, switched 24V-48V truck power as shown. Observe component polarity and follow instructions included with Voltage Filter.

NOTE: When installing on electric trucks, voltage filter 6061953 must be installed. Failure to install voltage filter can cause damage to electrical components.

- 3 Connect the four pin connector to the user supplied Light Bar wiring. **NOTE:** Connector Pin 4 is ground.
- 4 Connect the CAN L and CAN H wires to the truck CAN system.
- 5 Check the cable routing for pinch points and clearance. Use wire ties as needed.
- 6 Test the electrical circuits to assure correct accessory operation before returning the truck to service.

CAUTION: On electric trucks, assure that the power source into the CAN Reader, including ground, comes from a suitable capacity DC-to-DC converter. **Do not use the truck chassis as ground.**

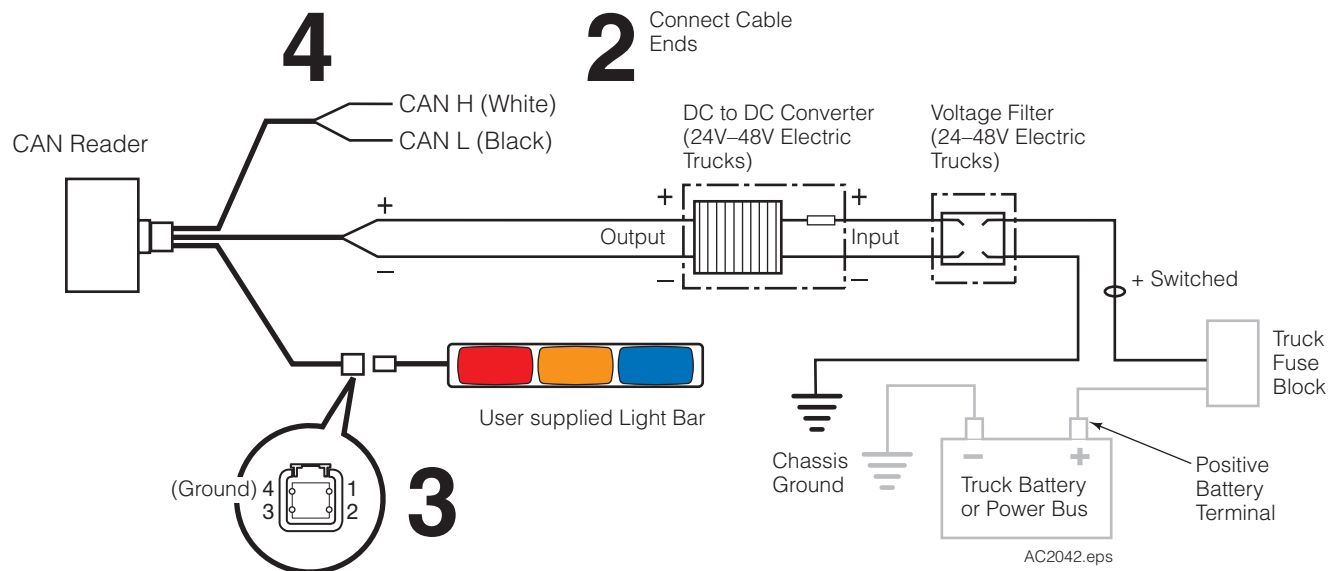

cascade[®]
corporation

For Technical Support . . .

Call: 1-800-227-2233 Fax: 1-888-329-8207
Internet: www.cascorp.com
Write: Cascade Corporation, PO Box 20187, Portland, OR 97294

To Order Parts . . .

Call: 1-888-227-2233 Fax: 1-888-329-0234
Internet: www.cascorp.com
Write: Cascade Corporation, 2501 Sheridan Ave., Springfield, OH 45505

Crown CAN Reader Kit

User supplied Light Bar

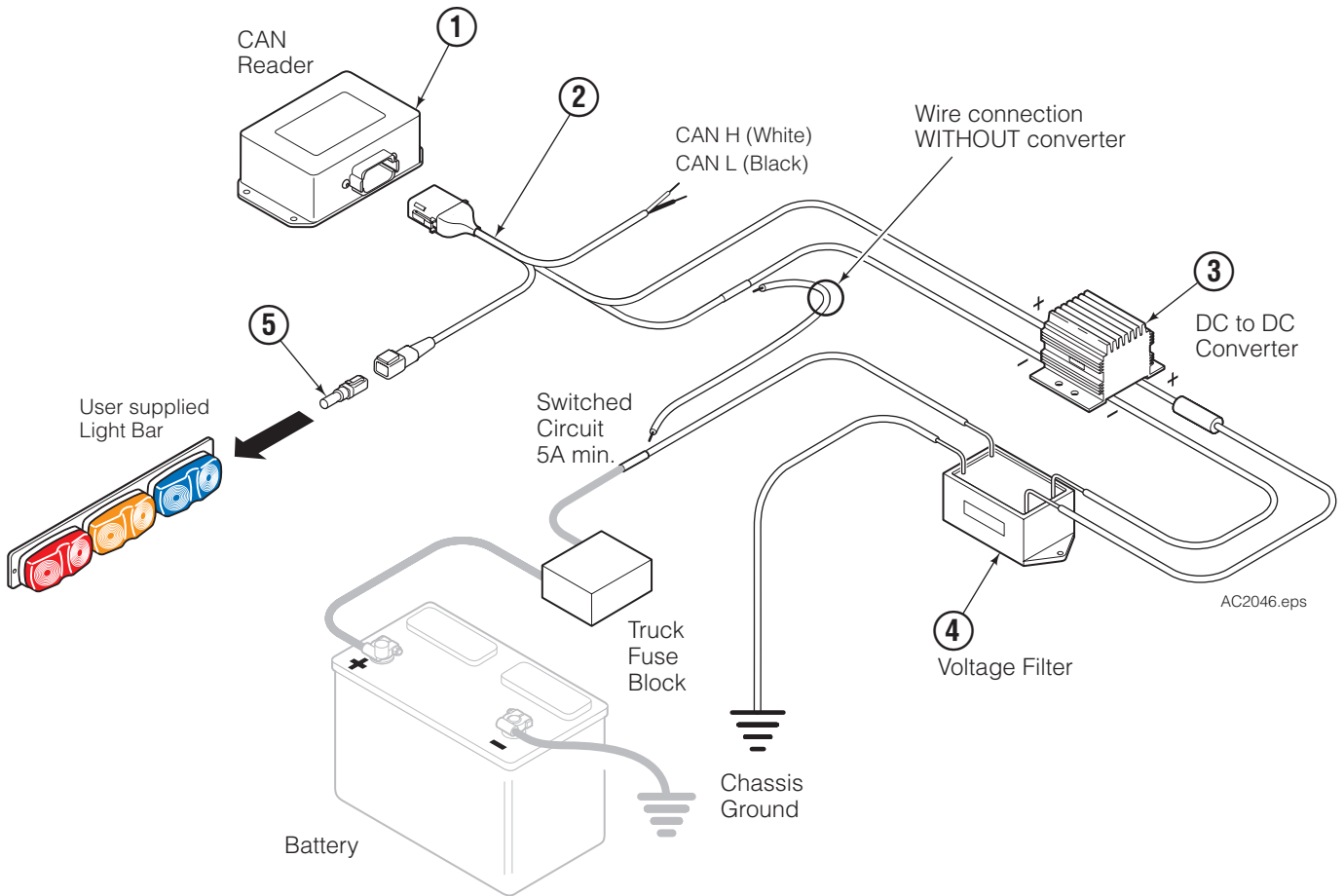

REF	QTY	PART NO.	DESCRIPTION
		6812924	CAN Reader without Light Bar
1	1	6812628	CAN Reader
2	1	6812659	Cable Assembly
3	1	6021069	DC-to-DC Converter, 24-48V→12V
4	1	6061953	Voltage Spike Filter
5	1	227249	Connector ▲

▲ Included with Cable Assembly 6812659 for convenience.
Use correct tool to crimp pins if needed.