

Technical Bulletin

G-Multiple Load Handler Slave Cylinder Upgrade

This sheet describes modifications to the frame and fork carriers to install new slave cylinders with 14 mm rod ends. Metal drilling and grinding is required to enlarge the mounting holes.



WARNING: Cascade Corporation recommends that a qualified mechanic experienced in this type of repair be used for best quality.

- 1 Disconnect hoses from slave cylinders. Tag hose ends for reassembly.
- 2 Remove the nuts from the slave cylinder rod and base ends. Remove the slave cylinders from the frame and fork carriers.

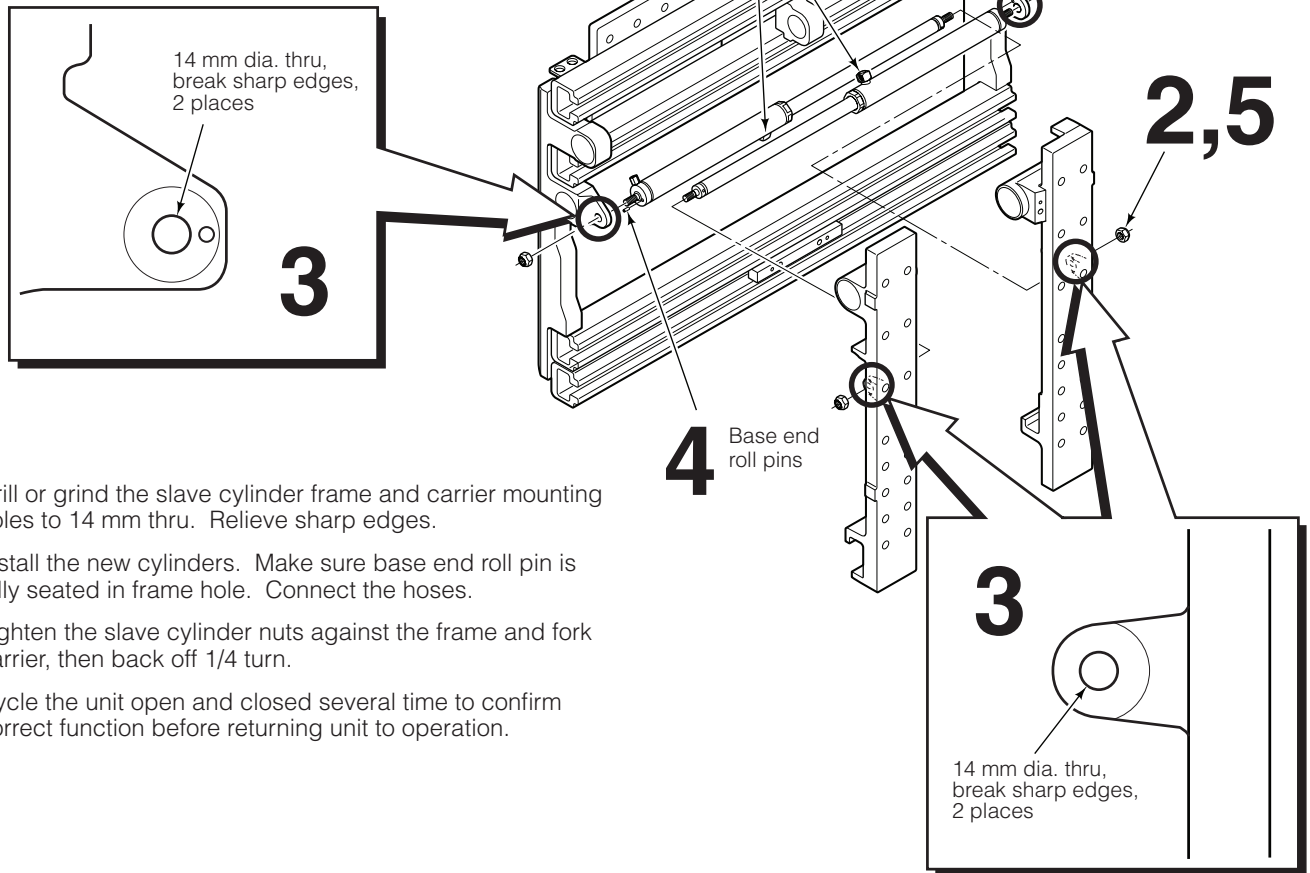

- 3 Drill or grind the slave cylinder frame and carrier mounting holes to 14 mm thru. Relieve sharp edges.
- 4 Install the new cylinders. Make sure base end roll pin is fully seated in frame hole. Connect the hoses.
- 5 Tighten the slave cylinder nuts against the frame and fork carrier, then back off 1/4 turn.
- 6 Cycle the unit open and closed several time to confirm correct function before returning unit to operation.

SD1088.eps

NOTE: This information should not be interpreted as the basis for warranty claims unless so designated.

cascade[®]
corporation

For Technical Support . . .

Call: 1-800-CASCADE (227-2233)

OR

Write: Cascade Corporation, PO Box 20187, Portland, OR 97294-0187

To Order Parts . . .

Call: 1-888-CASCADE (227-2233)

OR

Write: Cascade Corporation, 2501 Sheridan Ave., Springfield, OH 45505